



C600 RACK INSTRUCTIONS P/N C600FULL-1 / C600MINI-1

Package Contents:

PARTS

- (2) CROSS BARS
- (4) C600 LEGS
- (4) C600 HINGE ASSEMBLIES
- (4) LOAD SECURE POSTS

HARDWARE KIT

- (4) 3/8"-16 NUTS
- (4) 3/8" SPLIT LOCK WASHERS
- (4) 3/8"-16 x 1-1/2" HEX BOLTS
- (16) 5/16"-18 x 1" HEX BOLTS
- (16) 5/16"-18 SQUARE NUTS
- (32) 5/16" SPLIT LOCK WASHERS
- (8) 5/16"-18 x 1" CARRIAGE BOLTS
- (8) 5/16"-18 x 1-1/2" HEX BOLTS
- (8) SPACERS

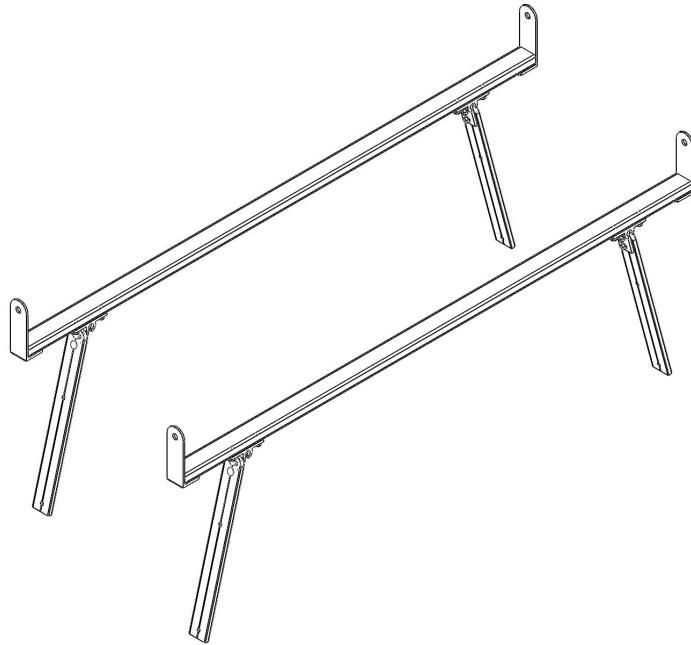

Before you begin:

Rack fits both straight and angled caps.

Remove all components from the shipping carton.

The rack should be assembled on a padded surface such as carpet to prevent scratching of aluminum surfaces. Remove bands securing components together.

Read the instructions thoroughly to familiarize yourself with the assembly sequence.

Note that you DO NOT tighten any nuts and bolts until the completed rack is installed on the vehicle unless specified. This allows for minor adjustments to the rack during the installation process.

Gather the following tools used to assemble and install the rack.

- 9/16" Socket or open end wrench
- 1/2" Socket or open end wrench
- 5/16" Drill bit and drill
- Pencil or marker
- Tape measure
- Center punch and hammer (optional)
- Level
- 2x4 Boards

1. Hinge assembly

Assemble the hinge assembly as shown using (4) 5/16"-18 x 1" hex head bolts, (4) 5/16" split lock washers and (4) 5/16"-18 square nuts.

Note the flat portion of the 5/16"-18 square nut faces toward the hinge. Repeat for remaining hinges assemblies.

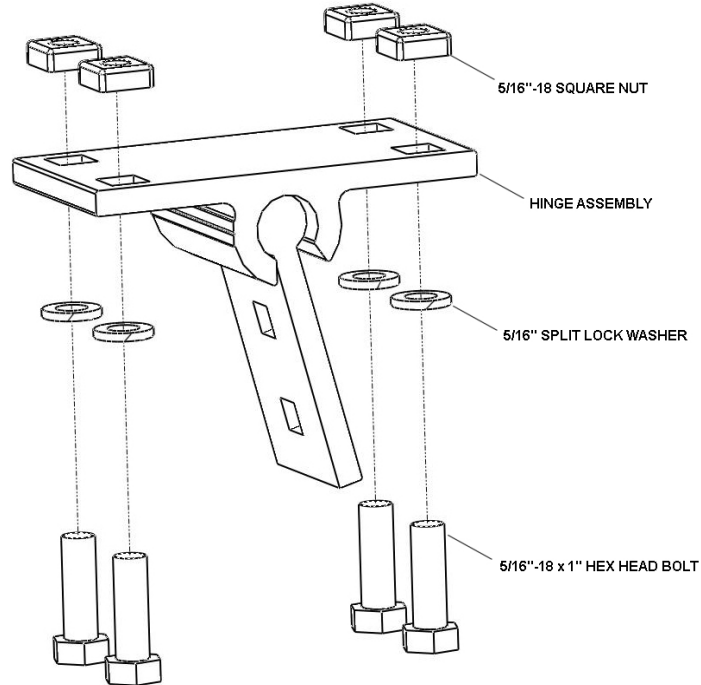

2. Leg assembly

Place the leg to the outside of the hinge assembly as shown.

Using (2) 5/16"-18 x 1" carriage bolts, go through the hinge first then the leg. Loosely secure the leg to the hinge with (2) 5/16" split lock washers and (2) 5/16"-18 nuts.

Repeat for remaining hinge assemblies.

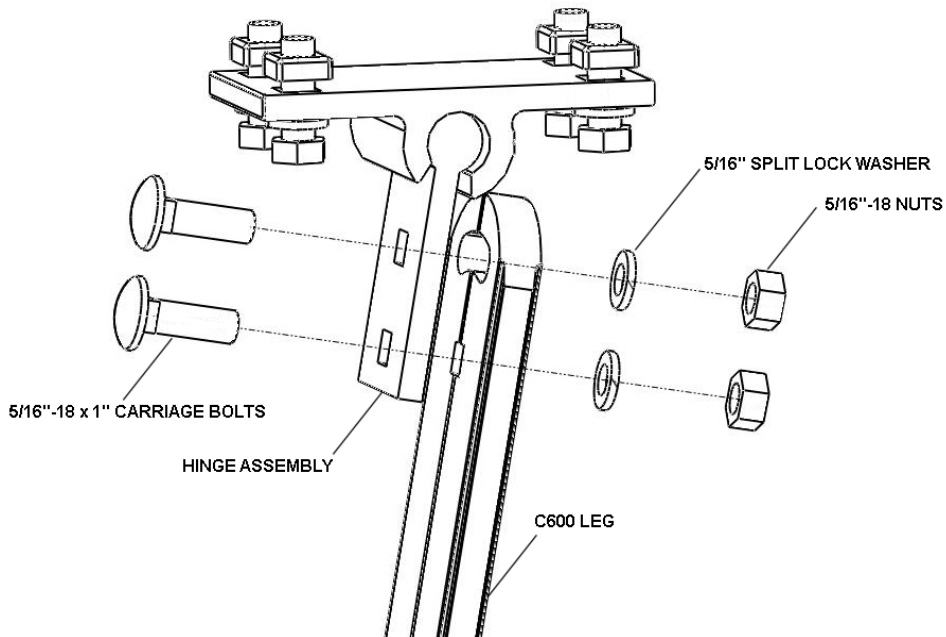

4. Crossbar assembly

Orientate the hinged assembly with leg as shown with the angle ends pointing away from the center of the crossbar.

Slide the 5/16"-18 square nuts into the outer channels of the crossbar.

Slide the assembly into the crossbar. Repeat for other side of crossbar.

Repeat for other crossbar.

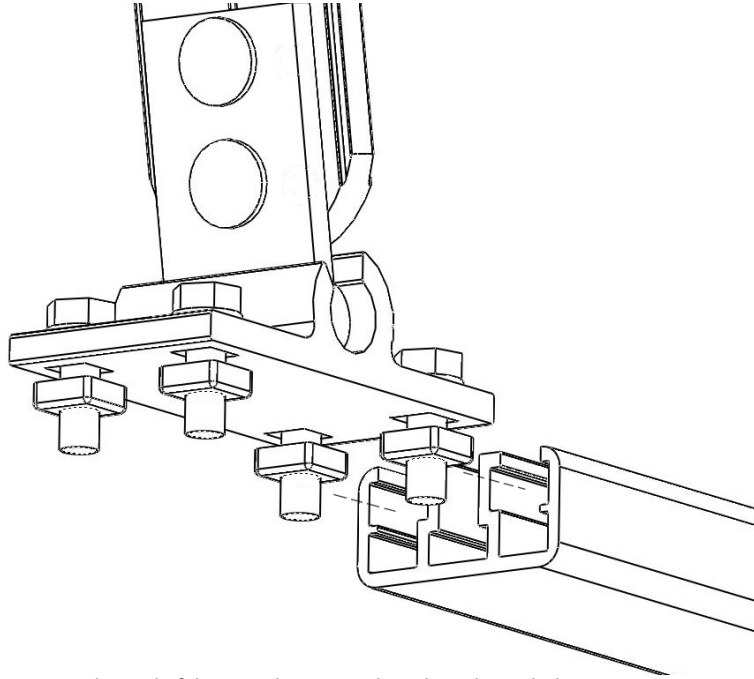

Slide in (1) 3/8"-16 x 1-1/2" bolt into the center channel of the crossbar on each end as shown below.

Repeat for other crossbar.



4. (Continued) Crossbar assembly

Install the load secure posts as shown. Place the end load secure posts so they are flush against the crossbar.

Tighten the load secure posts with 3/8" split lock washers and 3/8"-16 nuts and tighten hardware. Repeat for other crossbar bar.

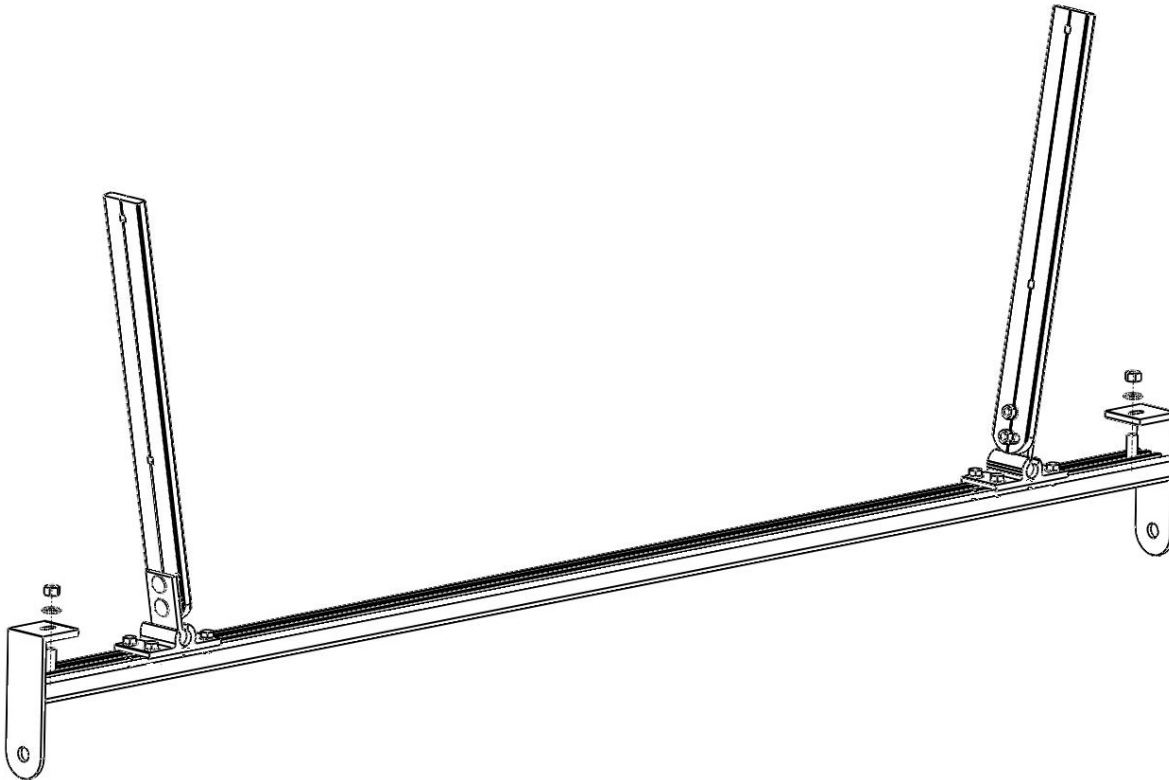

5. Mounting to cap

Place the rack assemblies on the cap to the desired positions. Place a 2" x 4" boards between the cap and crossbar to provide minimum clearance between the cap roof and bottom of the crossbar. The crossbars can be positioned higher if required.

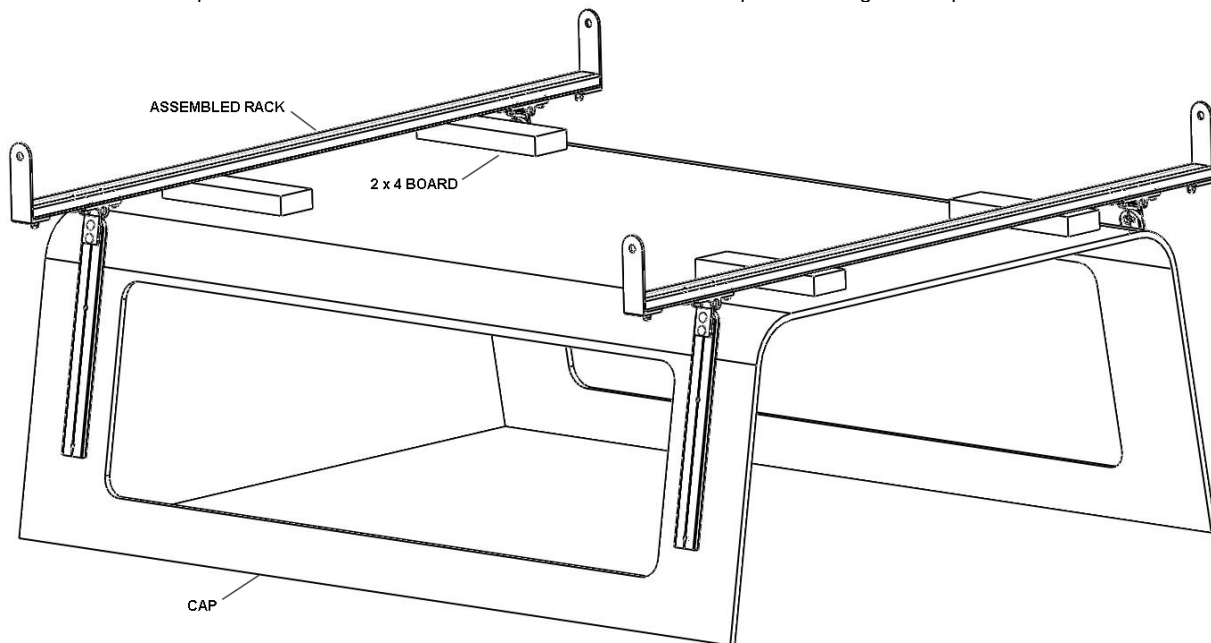

Check to make sure the front and rear crossbar assemblies are level with each other. Adjust if needed.

5. (Continued) Mounting to cap

Move the leg assemblies so they are flush against the cap. If needed, the angle of the legs can be adjusted to fit unique caps. Use a tape measure to center the crossbar over the cap for best results.

Mark the location of the square hole pattern of the legs onto the cap. Use a center punch to mark the center of the square hole for drilling (optional).

Drill 5/16" diameter holes through the cap at the mark locations.

Insert 5/16" x 1-1/2" bolts through the leg and into the cap.

Secure the leg on the inside of the cap using (2) spacers, (2) 5/16" split lock washers and (2) 5/16"-18 nuts.

Repeat for other legs.

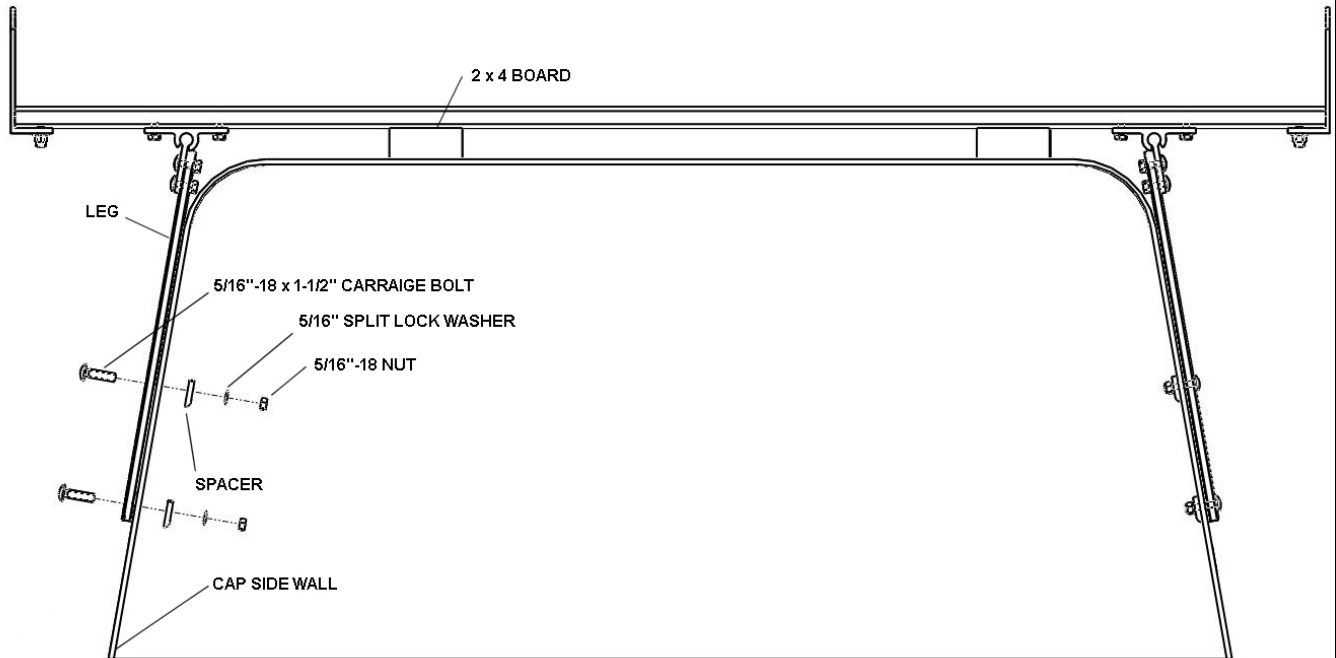

Tighten all nuts and bolts.

Remove 2 x 4 boards.

Customer Limited Warranty and Standard Return Policy

Hauler Racks, Inc. offers to preferred customers a special limited warranty. It is our goal to provide effective service for any warranty or standard return. This statement of warranty and return policy is divided into two sections: Warranty Returns of Defective Product and Standard Returns of Unused Product.

Warranty Returns of Defective Product

Hauler Racks, Inc. will repair or replace, at its option and without charge, any properly installed Hauler component that fails due to defect in material or workmanship up to 30 days from the initial registered consumer purchase. All of our aluminum product line is guaranteed not to rust or corrode for 1 year. Proof of Purchase must be provided for warranty to be honored.

Loads should never exceed 1/3 of your vehicle's manufacturer's total load capacity. Loads should never extend more than 1 foot on either end of rack. This warranty is void if any damage to the product is due to misuse, abuse, neglect, accident, improper installation, or any uses contrary to the instructions accompanying the product. The warranty is also void if racks are altered in any manner. The racks have been load tested for the racks capacity to hold loads when not on a vehicle. Hauler Racks, Inc. does not warranty load capacities. As the factory has no way of knowing if the product was properly assembled, installed, used according to instructions, or if loads were secured properly.

This warranty covers the cost of the defective component and not the cost of removal, installation or other incidental charges unless other arrangements have been made with Hauler Racks.

This warranty gives you specific legal rights and you may have other rights which vary from state to state.

All warranty claims must receive a Return Authorization number from Hauler Racks, Inc. BEFORE the product is returned to the Company. Please follow this procedure:

1. Call Hauler at 800-843-5445 to request a Return Authorization number. You will need to provide the following information
 - Specific nature of the defect
 - Product installation date
 - Product part number
 - Original sales invoice number
2. When a replacement or repair strategy is determined, a Return Authorization number will be assigned to the claim.
3. A replacement invoice and shipping document will be generated at Hauler Racks to initiate any replacement product. Replacement product will be sent according to standard shipping cycles.
4. The purchaser is responsible for packing and return shipping of the product. The RETURN AUTHORIZATION NUMBER MUST BE CLEARLY MARKED ON THE OUTSIDE OF THE PACKAGE. Unmarked packages will be refused. Any product damage that occurs during the shipping is not covered under warranty. The purchaser must pursue claims for shipping damage with the shipping center.
5. The purchaser is responsible for payment of both the original product invoice and the replacement invoice according to established credit terms.
6. Upon receipt of the returned product, Hauler Racks will review the claim for warranty conformance. If the claim meets warranty criteria, a credit for the original invoice amount will be posted to the purchaser's account and a credit memo will be mailed. If the claim does not meet warranty criteria, the purchaser will receive a statement detailing reasons for partial credit or denial. At the purchaser's option, denied product may be returned to the purchaser.

Standard Returns of Unused Product

Unused product may be eligible for return to Hauler Racks, Inc. Follow the procedure described in the section on Warranty Returns to receive an Authorization Number.

Returned product which is less than 6 (six) months old is subject to a 20% restocking fee.

Returned product which is more than 6 (six) months old may not be eligible for return or may incur additional restocking charges.

HMIS15
C600 FULL & MINI
Revised 8-18-2008

Toll Free: 1-800-843-5445
Phone: 763-546-5620
Fax: 763-546-0933
WWW.HAULERRACKS.COM